

A2/USD and MAB/MEGATRON ENCODERS

2 types of encoders are available and connectable to the RS485 port of the EME System interface. The US Digital encoder is more expensive but very accurate and more stable.

The MAB or ETS encoders from Megatron are low cost.

1. US Digital ENCODERS

1.1. A2 type

The A2 type encoders supply absolute position information to the interface board. These encoders are more expensive but they never need to be periodically calibrated.

The encoders are supplied with free setup software. The encoders must be set to the maximal resolution (65535) and mode 0 (any option checked). Show the following example:

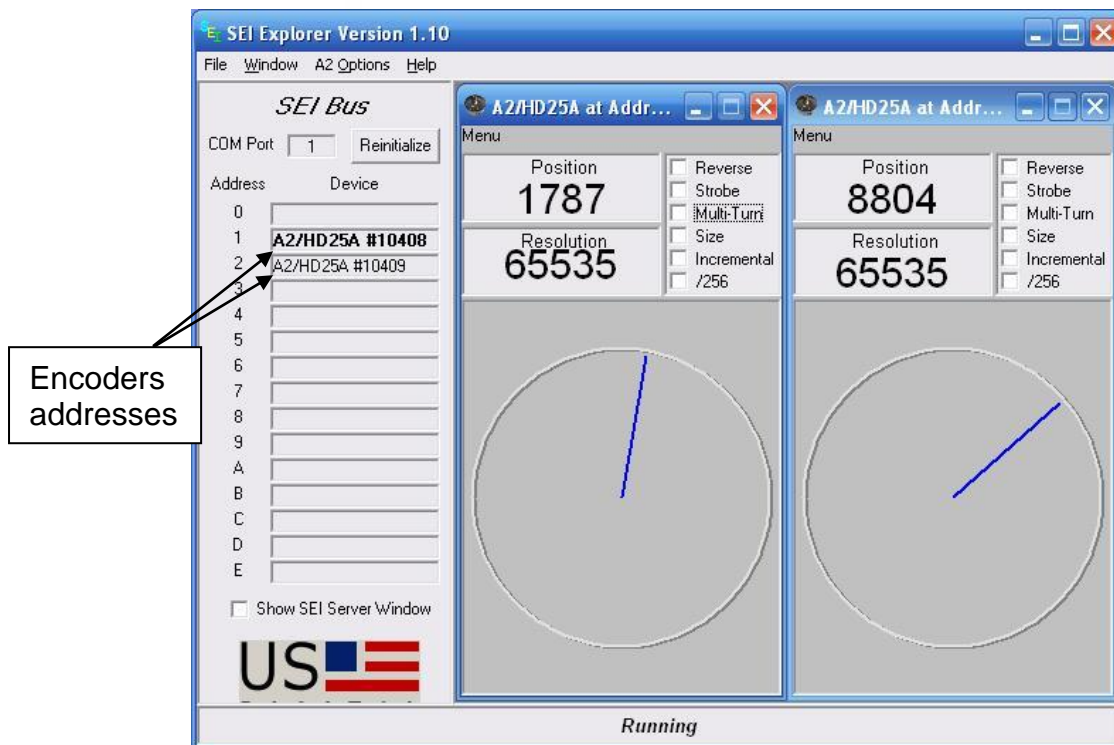
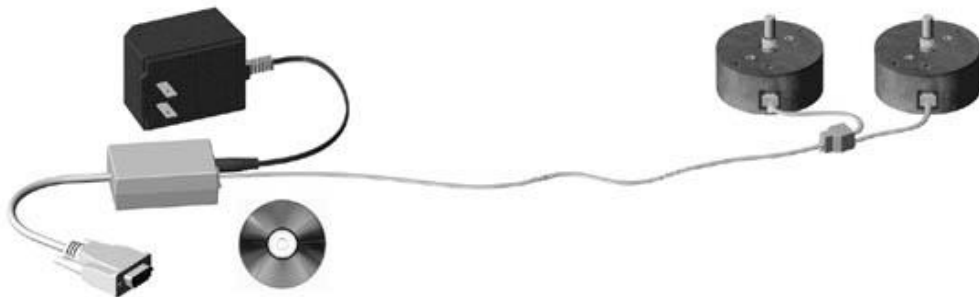

The A2 encoders type have to be used for Azimuth or Elevation. But it is possible to use the A2T (or A2I) for Elevation (Inclinometer).

With the SEI setup software and an adaptor SEI bus / USB you must set the resolution, the mode and the addresses of both encoders:

- Address = 1 for Azimuth
- Address = 2 for Elevation

You can also specify these values when ordering.

1.2. ORDERING INFORMATION

Your antenna design can be done with different configuration, like 2 * A2 encoders for Azimuth and Elevation or 1 * A2 encoder for Azimuth and 1 * A2T for Elevation. You will need also cables and connectors. Find below a list of the components I have used for the development and tests of the new MK-EHN interface:

- 2 encoders A2 (Ref A2-S-S) or A2T (2d generation). There are some options available when ordering :
 - 1st S for SEI Bus
 - 2^d S for Sleeve bushing
 - The other letters of the part number should be D for Default but
 - The USD website will help you in the configuration
 - For the [A2 encoder](#)
 - For the [A2T encoder](#)
- 1 connector 3 ways – 6 pins RJ12 to connect 2 encoders to the interface



- 3 cables (26 AWG) 6 pins + connectors [CA-MD6-SH-MD6](#) 6-Pin Modular Connector / 6-Pin Modular Connector, Shielded Cable. See also the paper "USD_advice.pdf" for more information.
- 1 adaptor SEI bus / USB to program or test your encoders. See <https://www.usdigital.com/products/interfaces/pc/usb/SEI-USB>

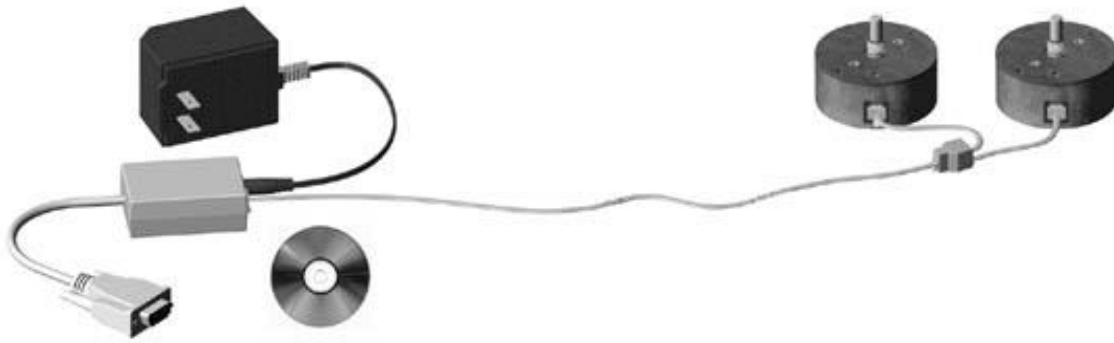

You will find more information on the US Digital web site:

- US Digital : <http://usdigital.com>

1.3. Connecting to the MK/EHN interface

The following picture shows the very simple connecting of the US Digital encoders to the interface:

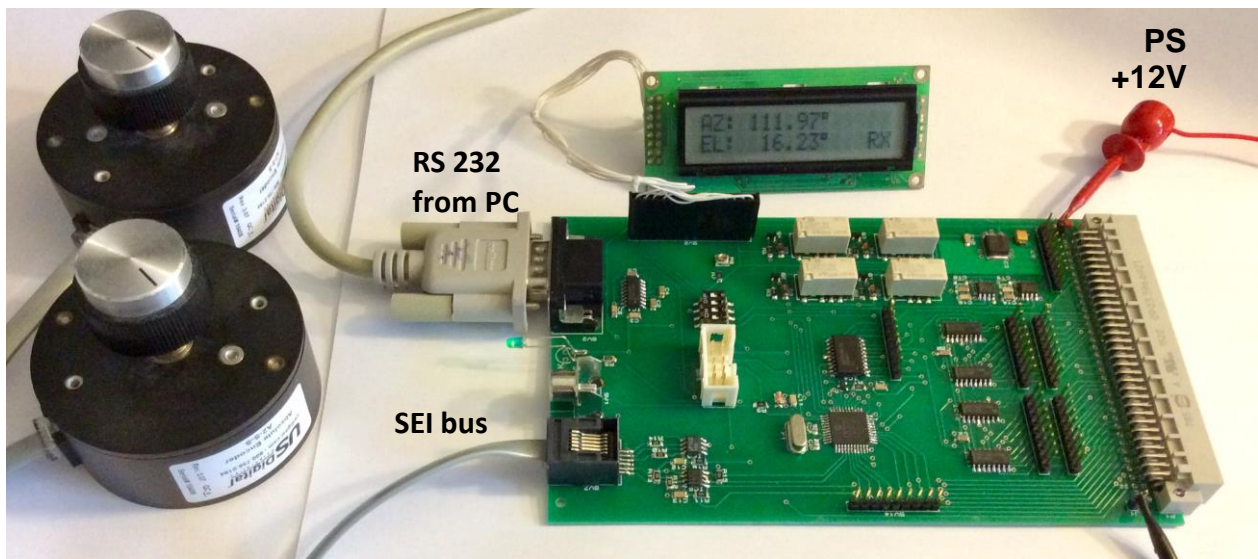

2. MAB25/ETS25 MEGATRON ENCODERS

The use of Megatron encoder is done via the small interface developed by Gary N8CQ. This interface allows to connect a Megatron encoder to the USD (RS485) of the EME interface.

The figure below shows 2 encoders Megatron ETS25 connected to the F1EHN board via 2 MABMPU interfaces.

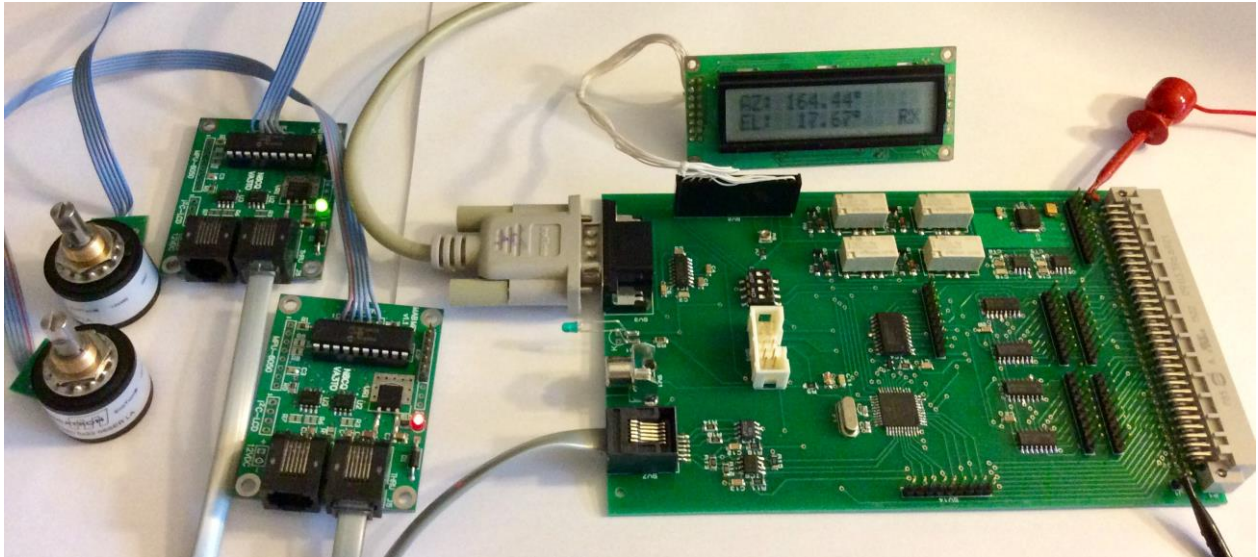

2.1 ORDERING INFORMATION

The encoders are manufactured by Megatron.

Data Sheet for Angle Sensors



Hall-Effect Singleturn Rotary Encoder with serial output

Series ETS25



ETS25 - R



ETS25 - F



ETS25 - L



ETS25 - K

- Serial micro controller interface (SER) or Serial Peripheral Interface (SPI) available
- Versatile electrical connections on demand: Solder- or clamping terminals, flat ribbon or round cable
- Compact Ø25 mm design
- Simple and time-saving bushing design

The high reliable Hall-Effect technology provides a constant signal quality over the whole life cycle..

The interface must be SER.

Find below a list of suggested components:

- 2 encoders ETS25 (new reference of MAB25). There are some options available when ordering :
 - SER bus
 - 5V
 - 12 bits
 - Reference : ETS25 - 6x22 - 05SER – LA (see order code information below)
- 2 cables 6 pins (Shielded Cable). The MABMPU allows to chain both encoders (see information on the schematic below)

Hall-Effect Singleturn Rotary Encoder with serial output						Series ETS25	
Order Code							
Description: Electrical angle: 360° Output signal: CW (clockwise) rising				Selection: standard=black/bold, possible options=grey/cursive			
Series ETS25		ETS25					
Shaft diameter, shaft length: Shaft diameter Ø 6 mm, shaft length 22mm Option: Shaft diameter Ø 6.35 mm, shaft length 22 mm Option: User defined shaft [mm] Ø ≤6.35mm				6x22 <i>6.35x22</i> <i>XxXX</i>			
Supply voltage / Output signal: 14 Bit / 5 VDC ± 10% / SPI 12 Bit / 5 VDC ± 10% / SER					05SPI <i>05SER</i>		
Shaft sealing (standard without shaft sealing): Option: D with shaft sealing					<i>D</i>		
Electrical connection, cable length, anti rotation pin (according drawing): (Standard) Flat ribbon cable standard length 0.15 m (drilling pattern compatible to the predecessor series ENA22, drilling pattern option B)						F0.15B	
Electrical connection, cable length, anti rotation pin (according drawing): (Options) Electrical connection: Option: solder pads (Only available for option 12 Bit / 5 VDC / SER) Option: clamping Terminals (Only available for option 12 Bit / 5 VDC / SER) Option: flat ribbon cable (Only available for option 14Bit / 5 VDC / SPI) Option: round cable (Only available for option 14Bit / 5 VDC / SPI) Cable length: Option: cable length in user defined length [X.XX m] (for option F und R, max. allowed cable length 1m) Anti rotation pin: Option: anti rotation pin A (anti rotation pin compatible to former series MAB25) Option: anti rotation pin B (anti rotation pin compatible to former series ENA22A)						<i>L</i> <i>K</i> <i>F</i> <i>R</i>	<i>X.XX</i> <i>A</i> <i>B</i>

About the interface and EME System freeware, more information on <https://f1ehn.org/>

Interface MABMPU – Gary N8CQ

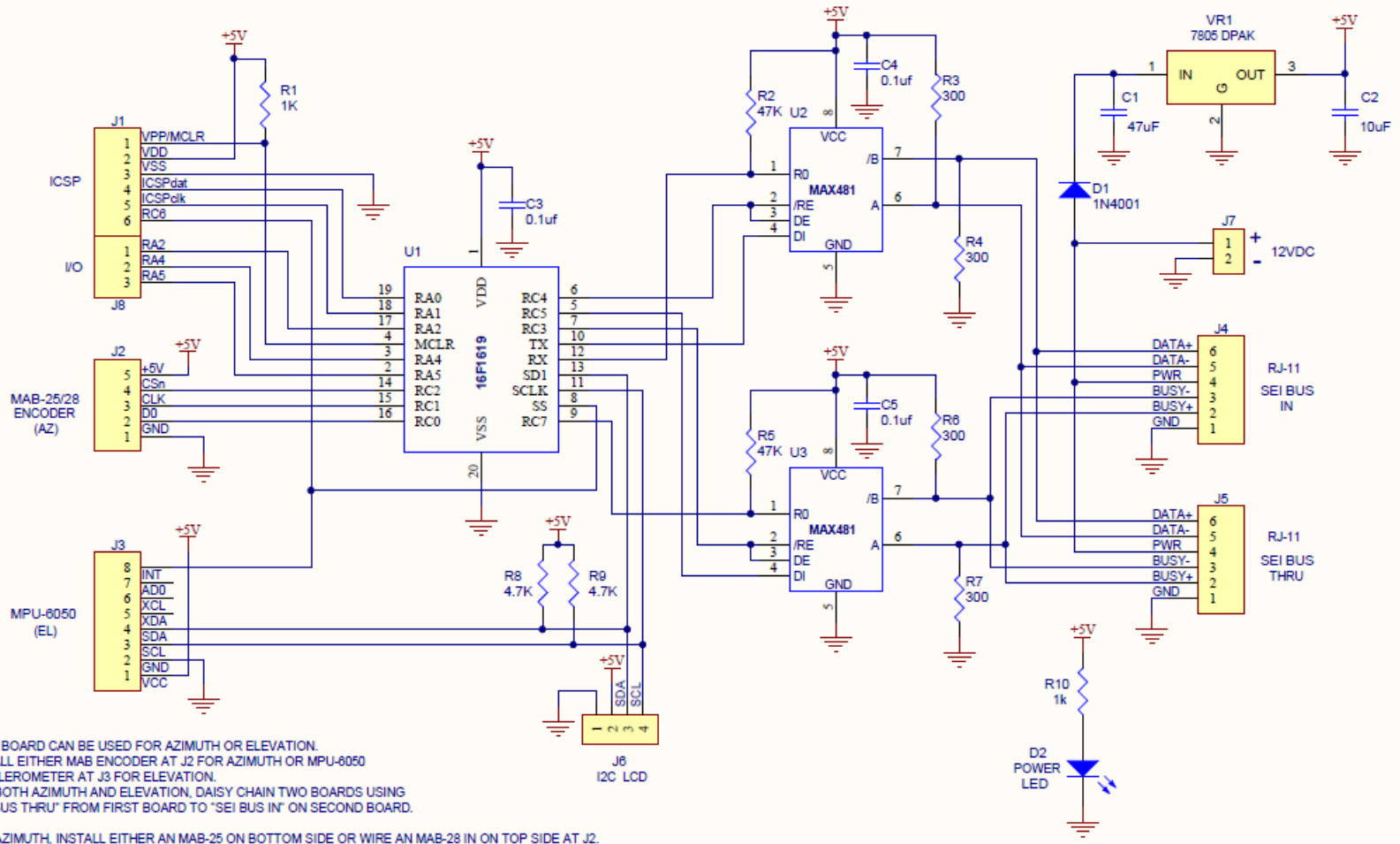

NOTES

- (1) EACH BOARD CAN BE USED FOR AZIMUTH OR ELEVATION. INSTALL EITHER MAB ENCODER AT J2 FOR AZIMUTH OR MPU-8050 ACCELEROMETER AT J3 FOR ELEVATION. FOR BOTH AZIMUTH AND ELEVATION, DAISY CHAIN TWO BOARDS USING "SEI BUS THRU" FROM FIRST BOARD TO "SEI BUS IN" ON SECOND BOARD.
- (2) FOR AZIMUTH, INSTALL EITHER AN MAB-25 ON BOTTOM SIDE OR WIRE AN MAB-28 IN ON TOP SIDE AT J2.
- (3) I2C LCD CAN BE CONNECTED TO J6 FOR REMOTE MONITORING.
- (4) POPULATE I2C PULLUP RESISTORS R8 & R9 AS REQUIRED.
- (5) SUPPLY 12VDC AT J7 WHEN NOT POWERED VIA SEI BUS AT RJ-11.
- (6) J8 IS AN EXTENSION OF J1 TO BRING OUT SPARE I/O PINS FOR FUTURE EXPANSION. FOR IN CIRCUIT SERIAL PROGRAMMING (ICSP), USE THE FIRST 6 PINS. WHEN NOT USED FOR ICSP, RA0, RA1 & RC6 MAY BE USED FOR I/O.

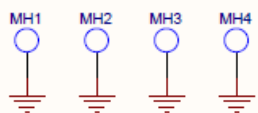

Title		MAB-MPU AZ/EL/LCD Board	
Size	Number	N8CQ / VA3TO	
A4			
Date:	27/01/2016	Sheet of	